

# ProLine 5200-Li

Custom designed for professional use with touch screen indicator



## BENEFITS

- Superb accuracy
- Rotating indicator
- 5 inch touch screen with 25 mm high digits
- High capacity Li-ion battery pack for 25 hours of autonomy
- Optimal ease of use, only active keys visible
- Customer specific routines can be programmed
- Integrated data connectivity
- Counting scale functionality
- Level compensation to 3 degrees
- Bluetooth 4.0 for RAVAS WeightsApp
- Connectivity software available

The hi-tech standard  
Extremely accurate



# RAVAS

## FUNCTIONS

- Automatic and manual zero correction
- Gross / net weighing
- Tare memory for 10 values
- ID-code entry for 4 ID-codes with 10 preset codes (each max.14 characters alpha-numeric)
- 10 totalizing registers
- Internal clock for date and time
- On board: RS232 port connection for printer  
USB output for data transfer (with USB Stick)  
Free COM 1 for Wifi, Bluetooth or RS232  
Free COM2 for Wifi, Bluetooth or RS232
- The USB output can also be used to connect a bar-code scanner
- Bluetooth 4.0 for RAVAS WeightsApp
- Sleep modes for saving power.
- Error message in display incl. logging

## STANDARD SPECIFICATIONS

- Capacity 2.000 kg
- Graduation multi-range  
0 - 200 kg: graduation 0,1 kg  
200 - 400 kg: graduacion 0,2 kg  
400 - 2.000 kg: graduacion 0,5 kg
- System tolerance 0.08 % of applied load
- Display full-colour 5" touch display with 25 mm high digits
- Power consumption 12V -160 mA
- Power supply Li-ion battery pack 14.8V / 5Ah incl. charger
- Autonomy 25 hours continuous use (50 hours with sleep modes)
- Keyboard display mode defines the available keys, on/off key
- Protection class Loadcells IP 67, indicator IP65
- Indicator mounting rotating and tiltable
- Steering wheels rubber
- Loading wheels polyurethane, tandem
- Pump ergonomic lift
- Own weight 180 kg
- Colour Chassis red (RAL3000)  
Fork shoe black (RAL9005)  
Epoxy painted

## DIMENSIONS IN MM

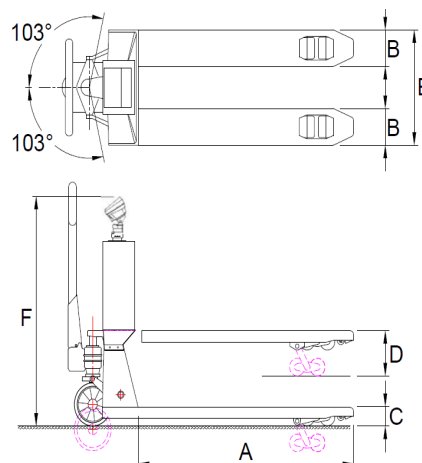

	Standard chassis	Stainless chassis
A Fork length	1150	1150
B Fork width	160	160
C Minimum fork height	90	90
Minimum clearance	22	22
D Maximum fork height	205	205
E Width over forks	550	550
F Height to top indicator	1260	1260
Loading wheels		
- type: PU tandem	yes	no
- type: PU single	no	no
- type: Nylon tandem	no	yes
Steering wheels		
- type: rubber	yes	no
- type: Nylon	no	yes



Management System  
ISO 9001:2015  
ISO 14001:2015  
ISO 45001:2018  
www.tuv.com  
ID 0000037200

## OPTIONS\*

- Legal for trade version, OIML III
- Extra exchangeable Li-ion battery pack
- Built-in thermal printer
- Bluetooth 2.0 or WiFi output
- Relay setpoint switch for automatic dosing
- Stainless steel fork shoes
- Stainless steel truck
- Reference scale via RS232 (for more accurate piece counting)
- 1D USB bar-code scanner
- Footbrake
- Different fork dimensions
- Different steering or loading wheels
- RDC, RAVAS Data Collector Software
- RIS, RAVAS Integration Software

### RAVAS Europe B.V.

Veilingweg 17, 5301 KM Zaltbommel, The Netherlands

T: +31 418 515220 E: salesoffice@ravas.com

WWW.RAVAS.COM

