

iPT Essential

New generation hand pallet truck

MOBILE
WEIGHING
SYSTEM

RAVAS iPT Essential

This hand pallet truck, equipped with the award winning RedBox technology, represents a new generation in mobile weighing and is designed with ease of use, reliability, ergonomics, uptime and innovation in mind, allowing end-users to benefit from an essential mobile weighing solution that optimizes their logistics processes and enhances efficiency.

BENEFITS

- 'Plug & Weigh'
- Ergonomic display on the handle
 - easy to operate with icon based display
 - easy to read, no influence of light
- 2,000 kg, 0.5 / 1 kg multirange graduation
- Rechargeable Li-ion battery for high up time due to long battery life
- Water tight for outdoor use
- 0-40°C operating temperature
- RAVAS System Care package;
standard includes gravity adjustment, load cell malfunction warning and overload warning

Top quality
For industrial use



RAVAS
creating intelligence

iPT Essential

FUNCTIONS

- Automatic and manual zero correction
- Gross/net weighing
- Totalling with sequence number
- Preset tare entry
- Integrated level correction
- Sleep mode with automatic start-up
- Overload protection 200% on mechanical construction
- Ultra low power display (to last over 1 year on batteries)
- Transport mode to lower power consumption

STANDARD SPECIFICATIONS

- Weighing capacity 2,000 kg
- Graduation multirange
0 - 500 kg; graduation 0.5 kg
500 - 2,000 kg; graduation 1 kg
- Max. tolerance 0.1% of the load lifted
- Battery
 - RedBox 3,7Vdc/5,2Ah Li-ion battery pack, charger and cable included
 - display 2 x 1,5V AA penlite batteries
- Battery life 6 months autonomy
- Charger (RedBox) standardized USB-C charger
230V/5V - 1 A
- Charging time approximately 6 hours
- Display EPD
- Protection class system IP65
- Steering wheels rubber
- Loading wheels polyurethane, tandem
- Colour red (RAL 3000), epoxy painted
- Pump quick lift
- Own weight 113 kg

OPTIONS

- Foot brake
- Steering wheels: polyurethane

DIMENSIONS IN MM

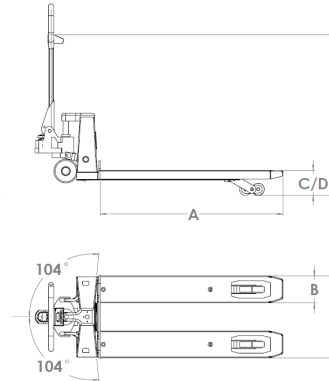

Standard

A	Fork length	1150
B	Fork width	170
C	Minimum fork height	85
	Space underneath fork	20
D	Maximum fork height	200
	Lifting height	90
E	Width over forks	540
F	Height to top indicator	1015
	Tolerance +/- 3 mm	



RAVAS
creating intelligence

RAVAS EUROPE BV

Veilingweg 17
5301 KM Zaltbommel
The Netherlands

+31 418 515220
salesoffice@ravas.com
www.ravas.com