

RAVAS-5200-F Li

Pallet truck scale with touch screen indicator

BENEFITS

- 5 inch touch screen with 25 mm high digits
- Power supply via Li-ion battery pack
- Optimal ease of use, only active keys visible
- Customer specific routines can be programmed
- Integrated data connectivity
- Counting scale functionality
- Level compensation to 3 degrees

Top quality

Customized functions



RAVAS

FUNCTIONS

- Automatic and manual zero correction
- Gross / net weighing
- Tare memory for 10 values
- ID-code entry for 4 ID-codes with 10 preset codes (each max.14 characters alpha-numeric)
- 10 totalizing registers
- Internal clock for date and time
- On board: RS232 port connection for printer
USB output for data transfer (with USB Stick)
Free COM 1 for Wifi or RS232
Free COM2 for Wifi or RS232
- The USB output can also be used to connect a bar-code scanner
- Bluetooth 4.0 for RAVAS WeightsApp
- Sleep modes for saving power.
- Error message in display incl. logging

STANDARD SPECIFICATIONS

- Capacity 2.000 kg (2.500 kg or 3.000 kg optional)
- Graduation multi-range
0 - 200 kg; graduation 0,2 kg
200 - 500 kg; graduation 0,5 kg
500 - 2.000 kg; graduation 1 kg
- Max. system tolerance 0.1 % of applied load
- Display full-colour 5" touch display with 25 mm high digits
- Power consumption 12V -160 mA
- Power supply Li-ion battery pack 14.8V / 5Ah incl. charger
- Autonomy 25 hours continuous use (50 hours with sleep modes)
- Keyboard display mode defines the available keys, on/off key
- Protection class Loadcells IP 67, indicator IP65
- Indicator mounting rotating and tiltable
- Steering wheels rubber
- Loading wheels tandem polyurethane
- Colour red (RAL3000) epoxy painted
- Pump quick lift
- Own weight 125 kg

DIMENSIONS IN MM

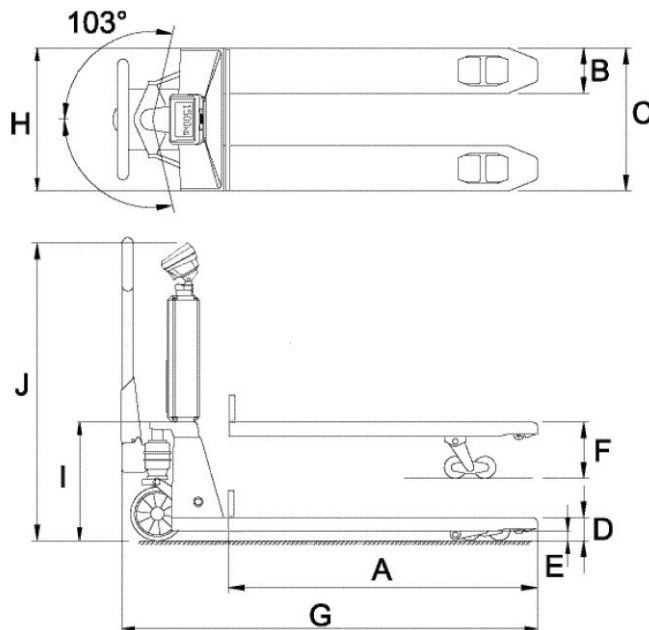

Standard

A	Fork length	1150
B	Fork width	180
C	Width over forks	555
D	Minimum fork height	90
E	Minimum clearance	22
F	Maximum fork height	205
	Lifting height	115
G	Overall length	1575
H	Chassis width	540
I	Minimal chassis height	405
J	Height to top indicator	950

Tolerance +/- 2 mm



OPTIONS*

- Legal for trade version OIML III
- Thermal or matrix printer 12V
- Thermal label printer
- Bluetooth 2.0 or WiFi- data transfer
- Reference scale via RS232 (for more accurate piece counting)
- Footbrake
- 1D USB bar-code scanner, not in combination with legal for trade
- Additional Li-ion battery pack
- Premium quality steel or stainless steel chassis
- RDC, RAVAS Data Collector Software
- RIS, RAVAS Integration Software

RAVAS Europe B.V.

Veilingweg 17, 5301 KM Zaltbommel, The Netherlands

T: +31 418 515220 E: salesoffice@ravas.com

WWW.RAVAS.COM

RAVAS