

RAVAS-110

Hand Pallet Jack

MOBILE
WEIGHING
SCALE

Valuable time is wasted by moving materials to a centralized floor scale for weighing. RAVAS pallet jacks come standard with a scale so you can weigh while on the move. Perfect for shipping docks, warehouses, or piecework production lines, the RAVAS-110 guarantees an accurate weight reading of 0.1% and improves your operational efficiency.

Efficient, Reliable, Accurate

- Mobile weighing functionality
- 5,000 lb. weighing capacity
- Low power consumption
- Onboard digital, LCD screen

Effortlessly lift and drive
with handle controls

Weights are
displayed digitally
on easy-to-read
LCD screen



RAVAS-110

FUNCTIONS

- Low battery warning in display
- Auto shut off after 3 minutes of non-use
- Error messages in display
- Totalling with sequence number
- Gross/net weighing
- Automatic and manual zero correction

STANDARD SPECIFICATIONS

WEIGHT CAPACITY

- 5,000 lb

GRADUATION

- 2 lb

MAXIMUM INACCURACY

- 0.1% of load lifted

DISPLAY

- LCD, digit height 0.7"

KEYPAD

- 3 function keys, on/off button

PROTECTION CLASS

- Rubber

STEERING WHEELS

- Electromagnetic brakes

LOADING WHEELS

- Polyurethane, single

FINISHING / COLOR

- Epoxy coated / red, RAL3000

OWN WEIGHT

- 235 lb

POWER SUPPLY

- 4 x 1.5V AA-Batteries in battery drawer

BATTERY LIFE

- One Year, When Used 5 times a day

PUMP

- Quick lift

DIMENSIONS

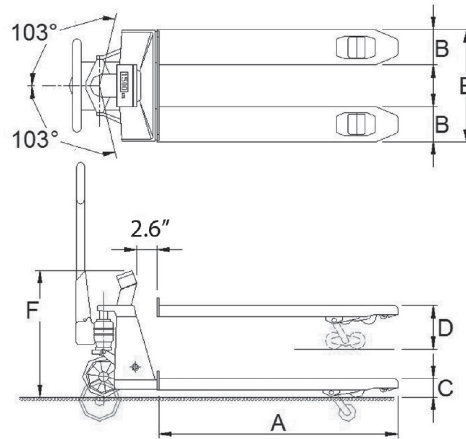

A	Fork length	48"
B	Fork width	7.1"
C	Width over fork	3.0"
	Ground clearance	0.7"
D	Maximum fork height	7.9"
	Lifting height	4.8"
E	Width over forks	27.2"
F	Height to top indicator	25.5"

OPTIONS*

- Integrated thermal printer
- Stainless steel chassis with polymer housing
- Width over forks 22"
- Foot brake
- Polyurethane steering wheels
- Nylon steering wheels

*The use of options may change related specifications.